

Fiat 370



FIAT
veicoli industriali



The Fiat 370

The Fiat 370 comes onto the market at a time when the problem of public transport is raising its head in a new form. This new model is not a chance event. The outcome of years of study and research, this coach represents an important milestone along the road of

Fiat Veicoli Industriali's unremitting efforts to solve the problems of public transport. The 370 is part of a far-reaching programme of technological development and product rationalization, whose ultimate aim is the building of a range of coaches to cater adequately for the new



why the 370 is an European coach.

requirements of collective transport. The programme mentioned has been developed by IVECO, the great European undertaking that combines the activities of five makes boast-

ing a technological tradition in the field of passenger transport: Fiat, OM, Unic, Lancia and Magirus-Deutz. The 370 is one of the products of this merger. And this is one of the reasons



The styling

The 370 has been given a new "line", an attractive, streamlined shape to improve drag coefficient and reduce passive resistance, thus ensuring lower fuel consumption. The coach's "beauty" and streamlining were the twin offspring of the wind tunnel

where innumerable tests have been carried out on models of increasing scale. Cooperation between engineers and stylists has produced a vehicle whose versions all possess the same styling and drag features.



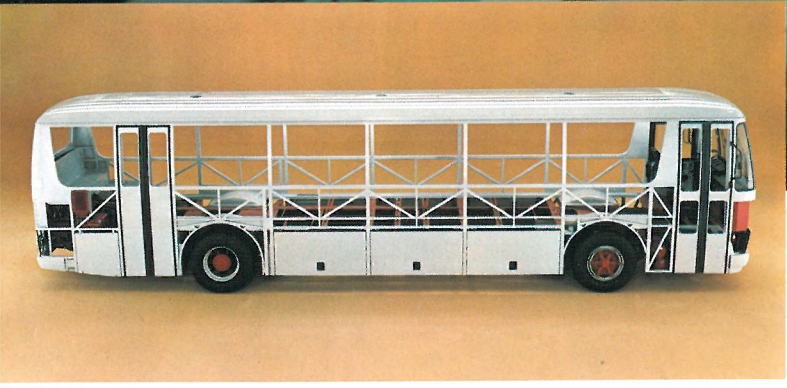
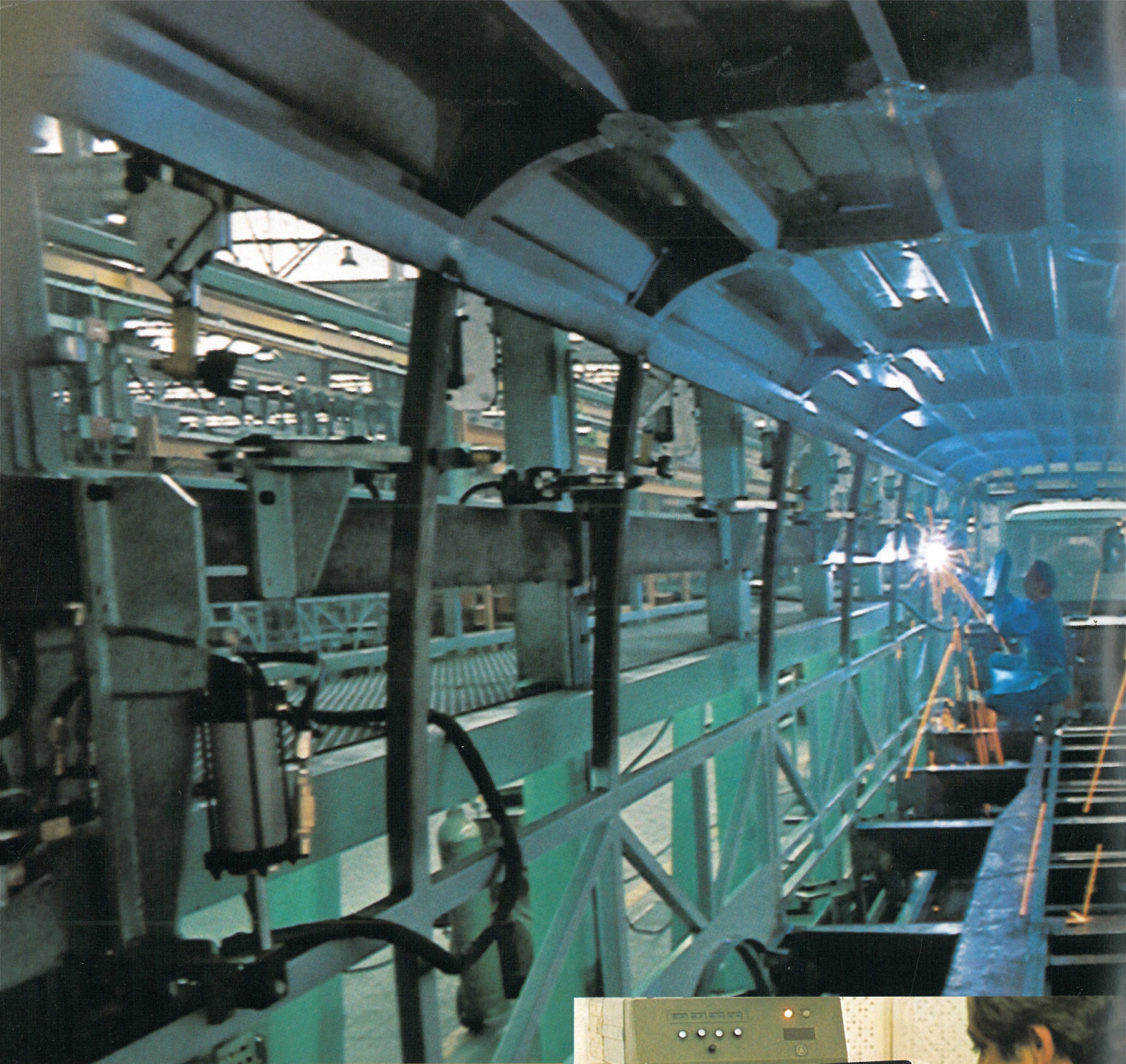

The body structure



The structure is the end-product of a series of stages and the expertise of Fiat Veicoli Industriali has been bolstered here by the results of the most recent experiments on materials carried out by

IVECO. The result is sturdy but light structures with top safety features (integral roll-bars, ribbed sides, etc.). The body framework, the steel sections of which are linked by specially

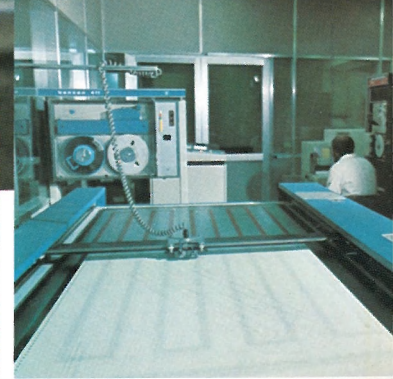
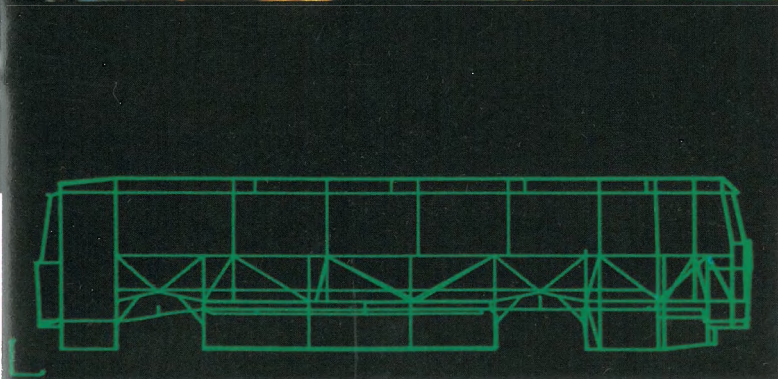

reinforced knots, is electrically welded to the main frame. The top quality materials employed have gone through the very latest anticorrosion treatment to guarantee strength and durability.

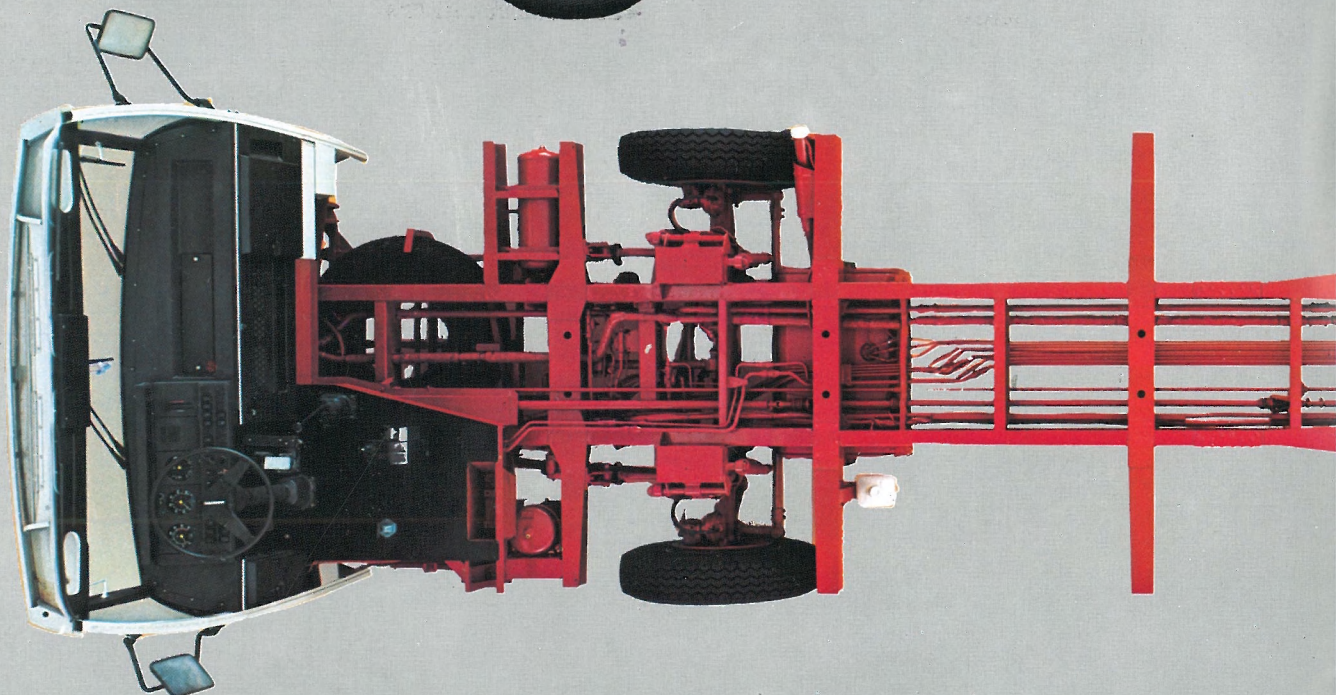
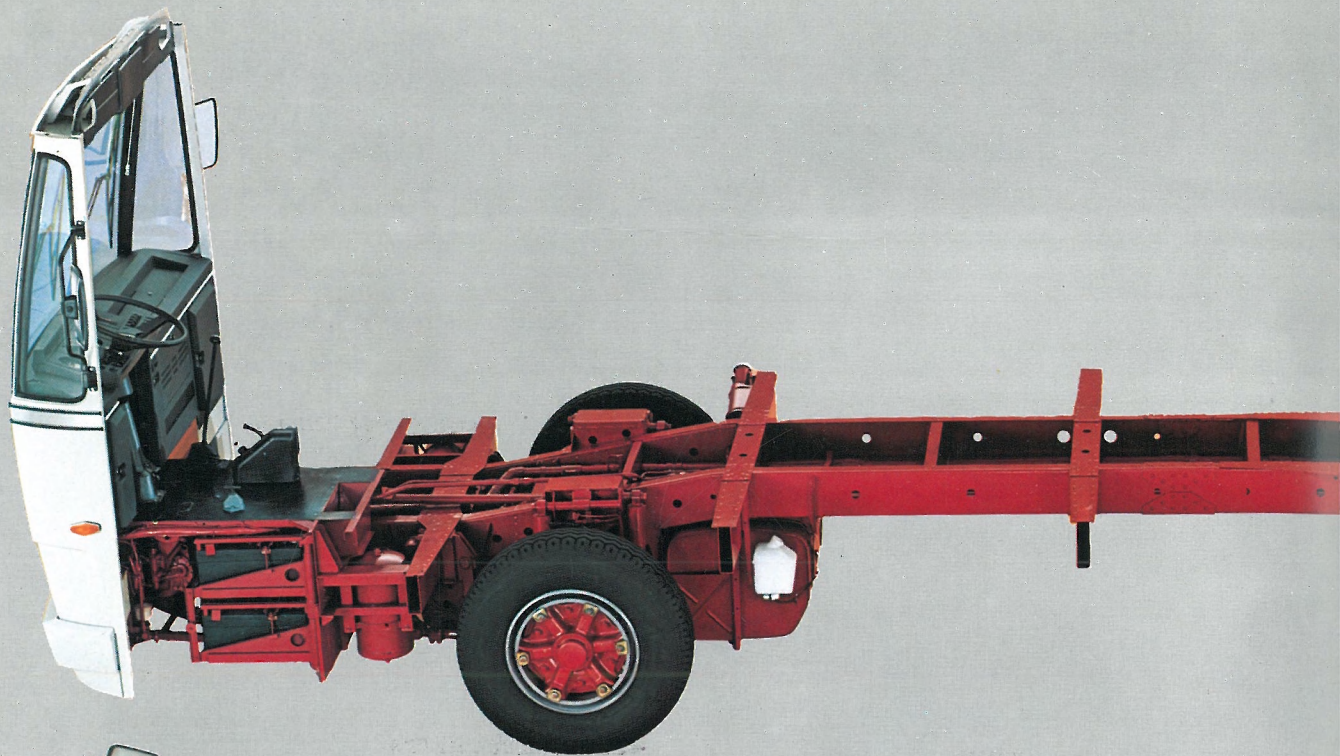

The chassis

For a product born out of a new industrial concept like the 370, the main frame structure is the key point in the modular construction process: the frame of the 370 consists of pressed side and cross members, while all mechanical assemblies are concentrated on the overhangs in the

interests of modularity, in other words to enable different wheelbases, different numbers of seats and different power plants to be combined, and to ensure maximum luggage capacity.

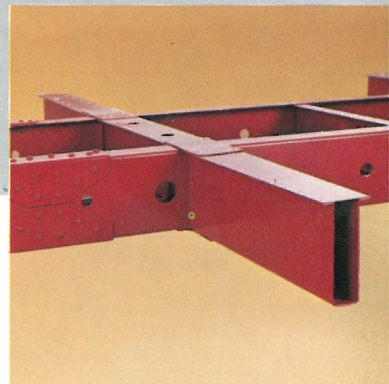
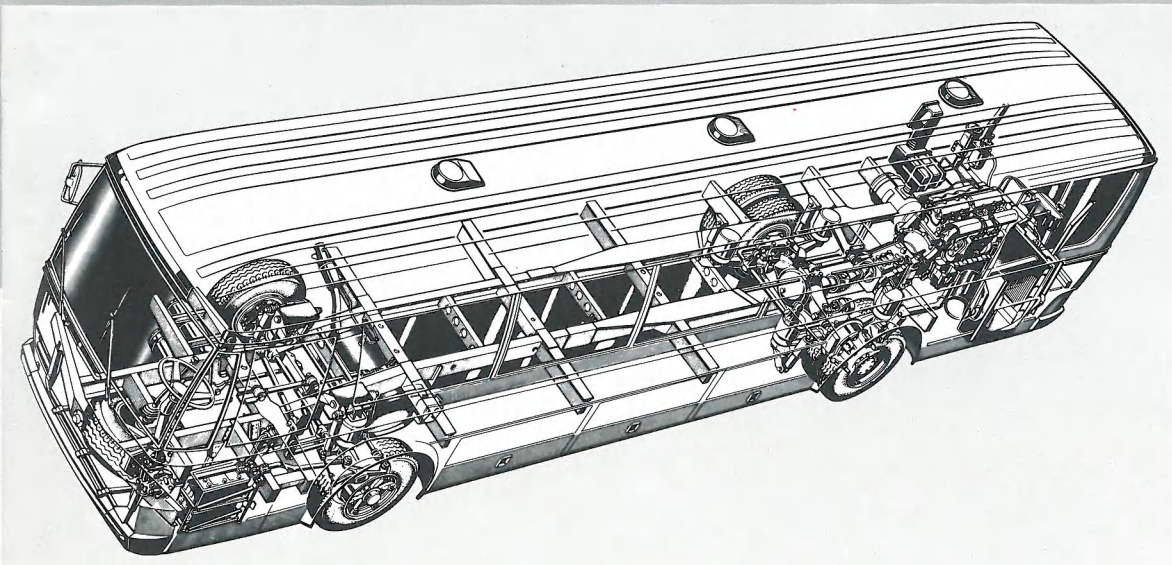
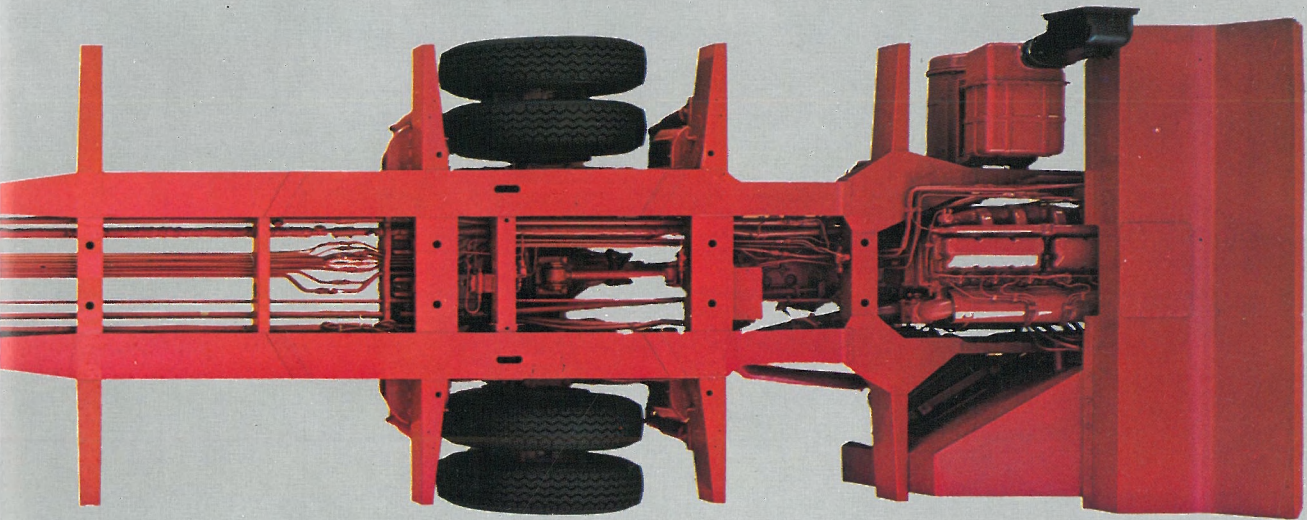
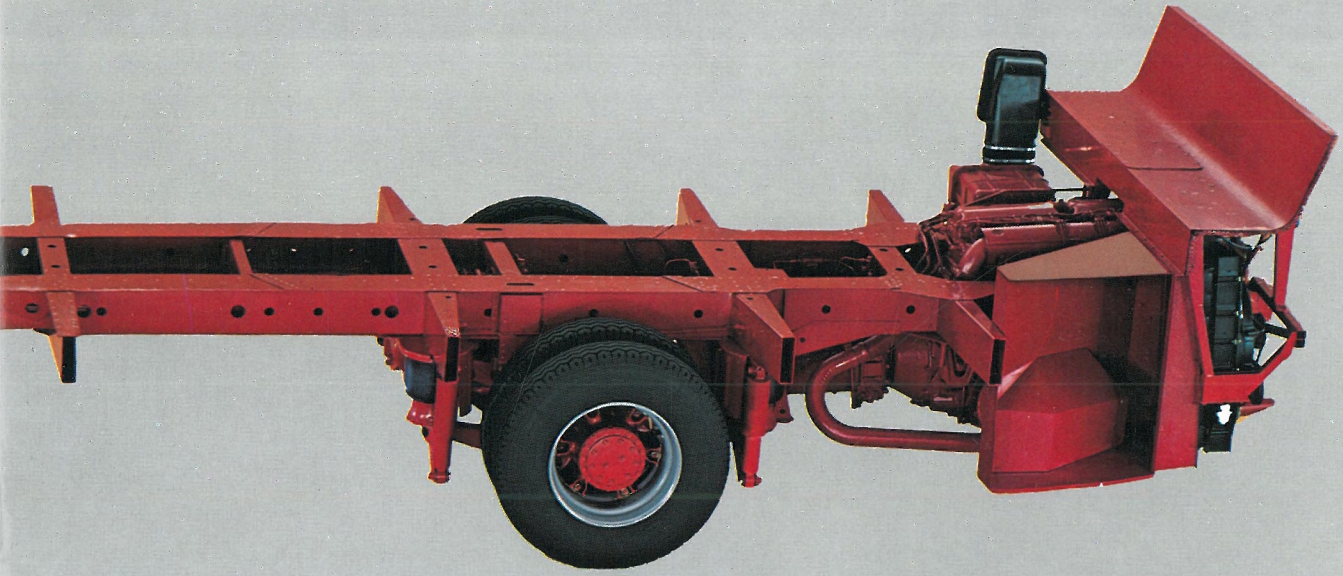

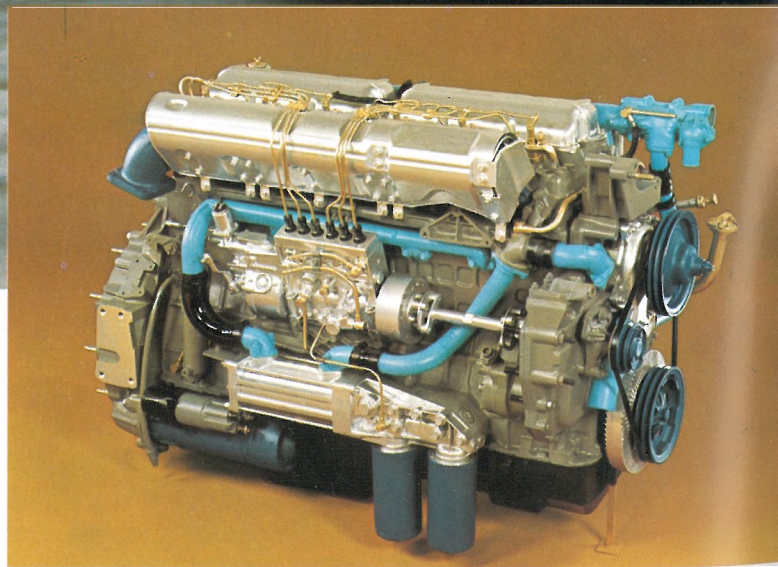
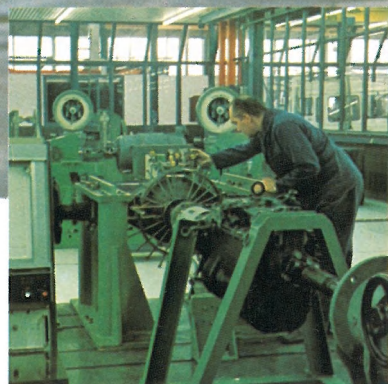
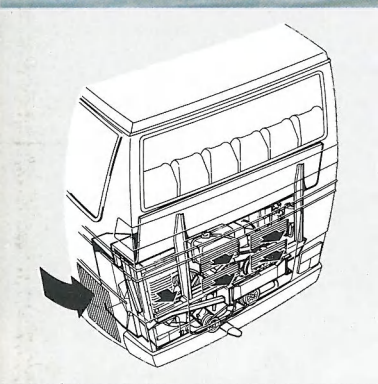

The engine
The suspension
The braking system

The engine
The 370 is fitted with a truck-derived engine, the popular Fiat 6-cylinder Diesel which produces 260 bhp (DIN) at 2200 rpm and which has offered ample proof of its

reliability. Its longitudinal position on the rear overhang makes for clear access in all repair and maintenance jobs. Cooling is by viscostatically controlled fan and large radiator.

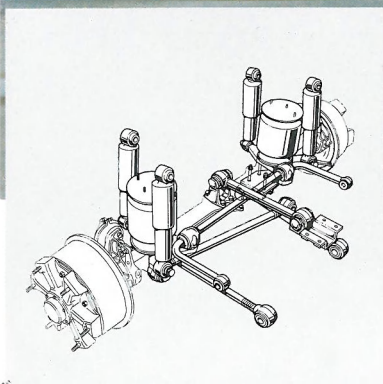

The suspension

Suspension is fundamental for passenger comfort. Those on the 370 are the outcome of an intense design and experimental commitment: they are of the all-air type. Continuous, automatic regulation of pressure within the air spring holds the coach

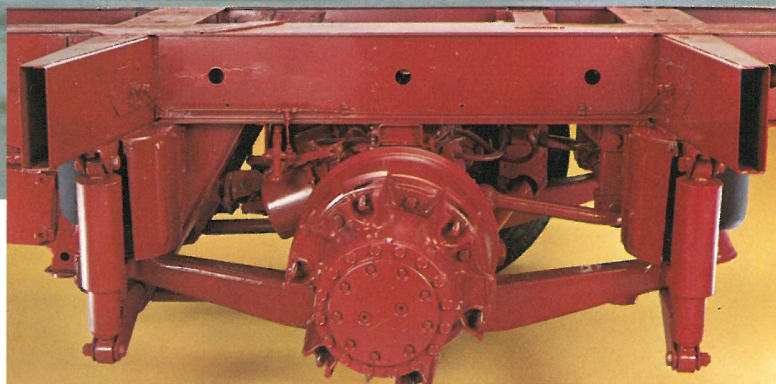

deck at a constant level whatever load conditions are and however uneven the road.

The braking system

Braking is of the all-air type with two independent circuits supplemented by a third adjustable vacuum circuit on springs, serving as a parking brake and extra booster. To round off the safety measures on the braking units, levers that automatically take

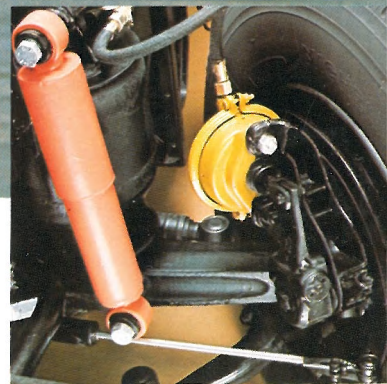

up shoe wear play have been fitted.



The tests

After laboratory tests had fully assured us of the coach's safety and strength, road tests were begun to assess its practical performance. Strength and manoeuvrability qualities were subjected to intensive functional testing. Finally, the 370's stamina and willingness were tested on

some really rough tracks, and it was made to cross muddy, salty fords, subjected to controlled skid tests and forced to tackle slaloms.



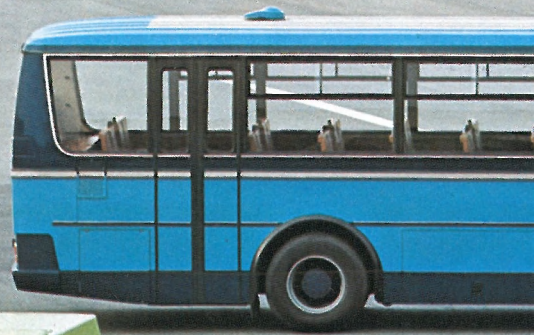

Service requirements

Designed to provide an adequate response to the new demands which are coming to the fore in collective transportation, the 370 keeps the needs of owners and passengers of today very much in mind.

It comes in four versions: inter-city, hire service, touring, de luxe touring.



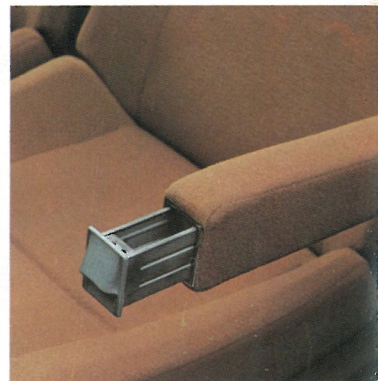
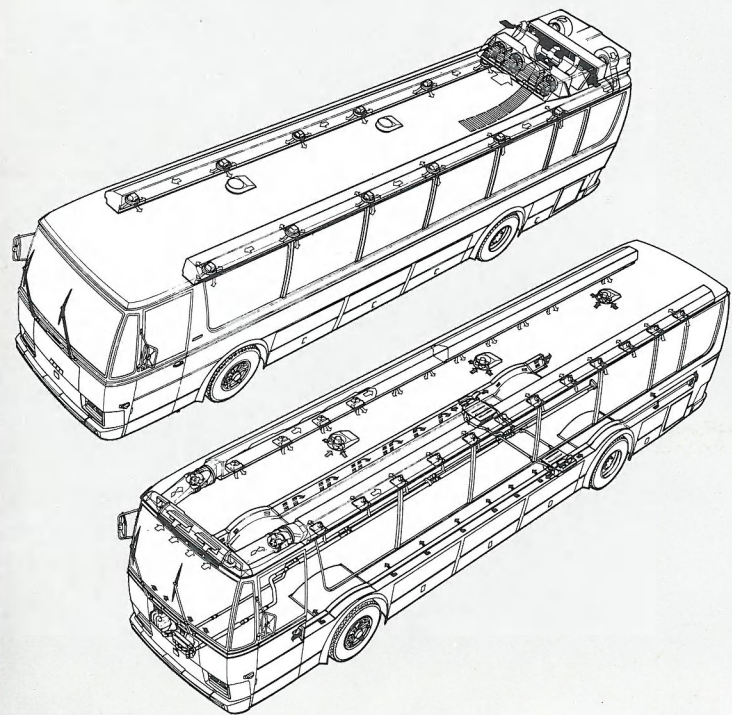

The comfort

The wares carried by coaches are very special and highly sensitive to the way they are carried. The bus-travelling public is destined to grow and expects greatest efficiency and comfort from the service. Before anything else, the 370 is equipped with the "overall

comfort" that comes from the vehicle's all-round quality and reliability. The huge passenger area with its vast window surfaces contains the comfort proper, that series of "little" luxuries and useful extras that make the 370 an attractive way to travel.







All versions enjoy the same first-class acclimatization, namely the hot-air heating system with below-floor units fed from the engine coolant circuit, and the ventilation system. The Touring and De luxe touring models have an individually regulated forced ventilation plant.

Thanks to the particular layout of the engine, steering and suspension assemblies, the luggage compartment is able to occupy the whole width of the coach. Enormous capacity in short, accessible through six doors, three on each side, which open upwards by oleopneumatic lift.



The Fiat 370 "inter-city" version

An inter-city coach, one in other words which is used on frequent short hauls, must be practical but without being unattractive or missing out on overall comfort qualities.

This version has the following features:

- double seat units with single fixed backs, headrests and cushions. Five seats at the rear with individual backs, headrests and individual cushions
- ample room for passenger movement



- neat interior finish
- large capacity luggage compartment.



The Fiat 370 "hire service" version

A coach that may have to cope with lengthy journeys, one which whatever it is hired for is always on the move, has to be safe, practical, manoeuvrable and comfortable. This is the 370 "hire service" version:

- double seat units with single fixed backs, headrests and cushions. Five seats at the rear with individual backs, headrests and individual cushions.
- five seats in the rear with individual backs and cushions
- ample room for passenger movement



- heating and ventilation plants (forced ventilation optional)
- fine interior finish with top quality materials
- large capacity luggage compartment.



The Fiat 370 "touring" version

During a day-trip or a full-scale holiday, the time spent in the coach should be part of the pleasure; so the ride should be as comfortable as possible, undisturbed and safe. And passengers must not get tired.

This is the 370 "Touring" version:

- double seat units with single fixed backs, headrests and cushions. Five seats at the rear with individual backs, headrests and individual cushions
- ample room for passenger movement

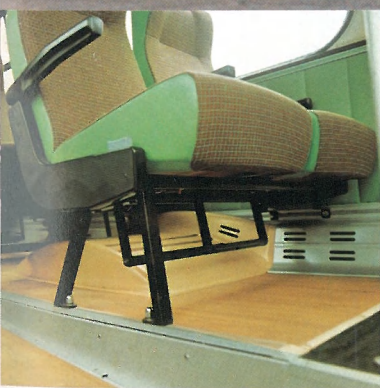

- heating and ventilation plants (forced ventilation optional)
- elegant interior finish with top quality materials
- radio equipment can be installed and loudspeakers supplied and fitted
- large capacity luggage compartment.



The Fiat 370 “de luxe touring” version

A coach for long-distance touring, a coach of high quality.

The coach where everything is attractively warm and comfortable:

- double seat units and individual reclinable backs with individual headrests and cushions. Three lift-up armrests on each seat. Four seats at the rear with the same features



- seat-back grip, ash-tray and map pocket for each seat;
- ample room for passenger movement
- independent heating plant
- forced ventilation plant with piping above side lights. Individually regulated operation
- air-conditioning system

- optional
- high quality furnishing fabric finish
 - large capacity luggage compartment.

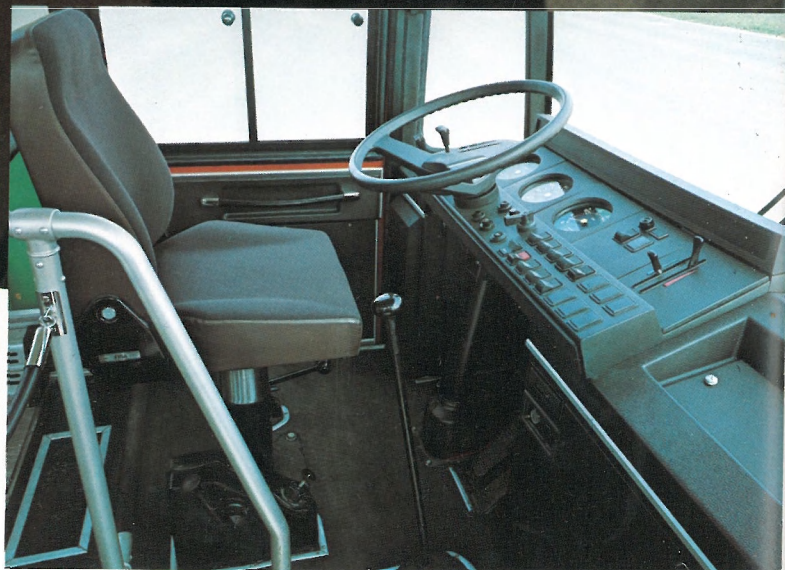
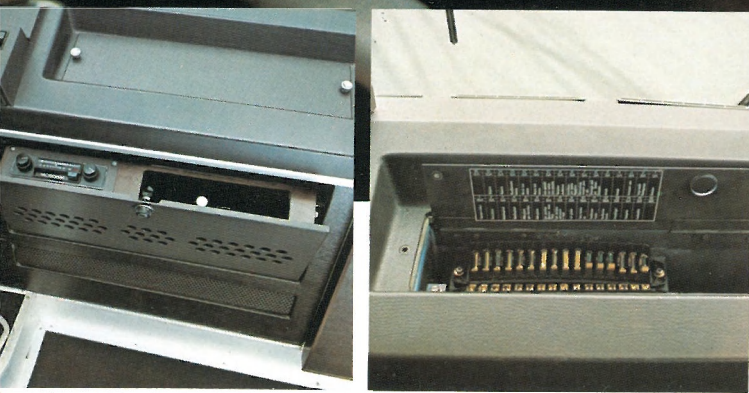

Driving comfort

The driver is an important passenger and the conditions in which he works concern everybody else in the coach. In designing the 370, ergonomic and physiological studies, laboratory and road

tests have been devoted to the problem of the driving position. An ideal driving "environment" has thus been created. The instruments are easy to read and the particular position of the engine enables the

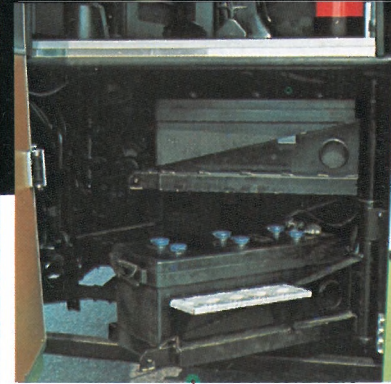
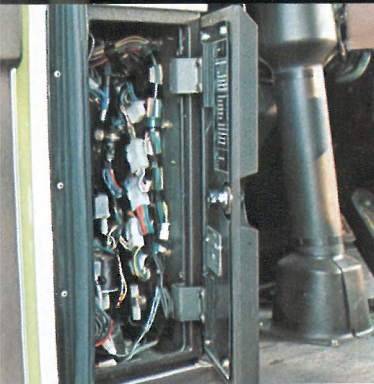

driving seat to be isolated from vibration and noise; the seat is adjustable for height and reach to suit any driver requirements. The heating and ventilation

plants are, of course, another benefit the driver enjoys.

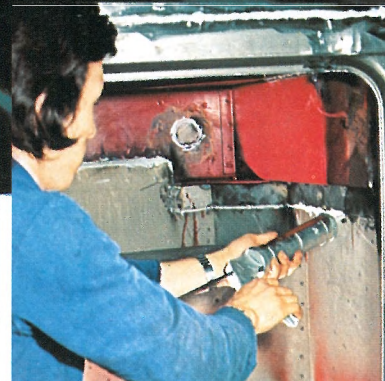
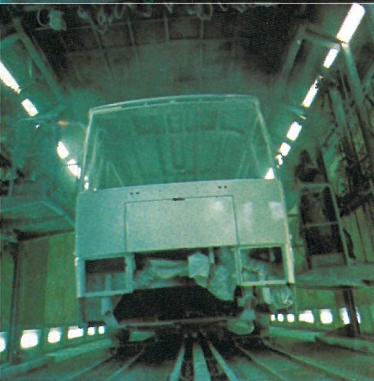
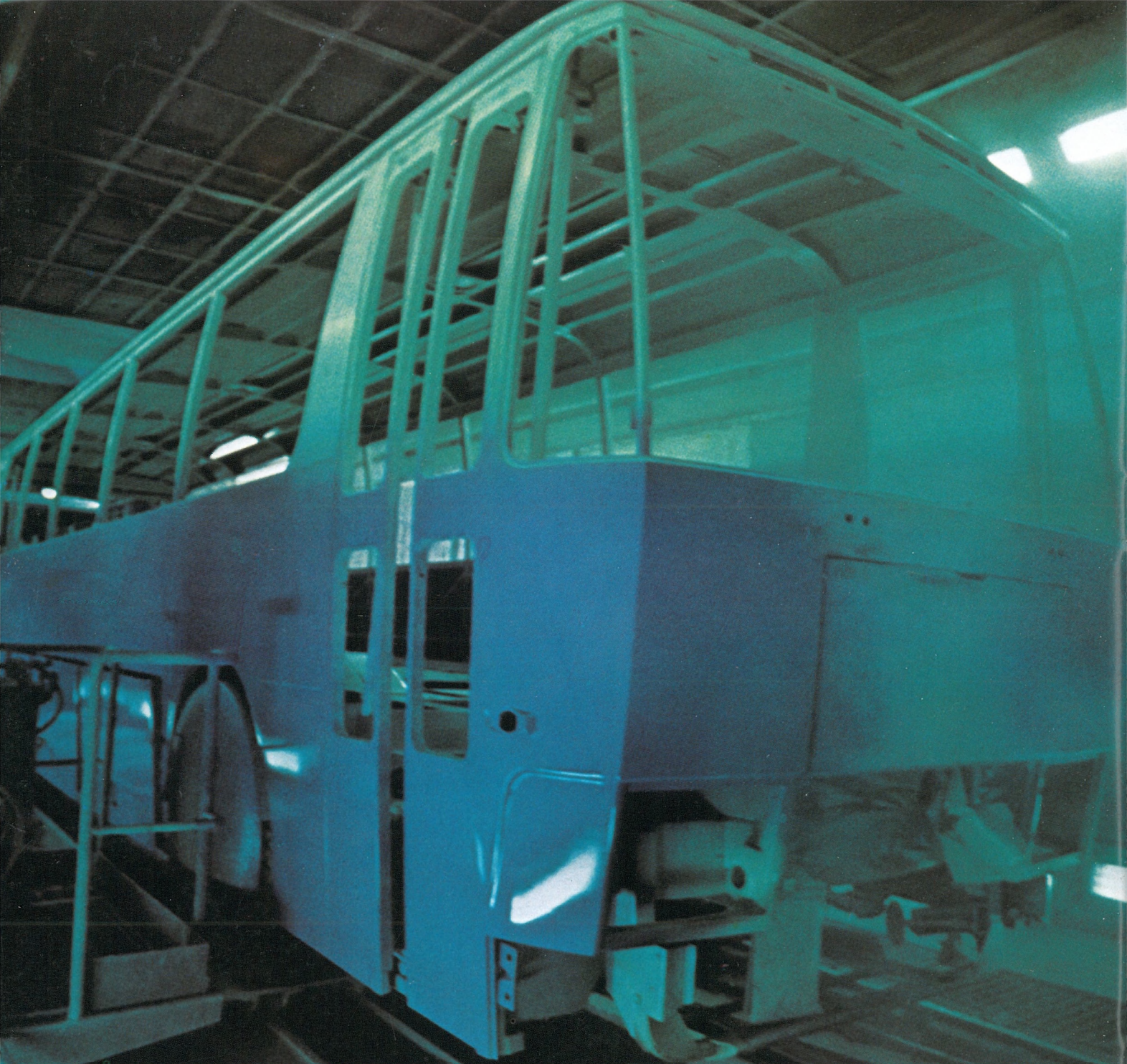

Painting

Painting has a technical and scientific as well as an aesthetic function, insofar as it protects and guarantees long life for the whole of a vehicle structure. And it also has an economic function: since a vehicle should last for many years it will help its owner save money. Special attention has been

given to painting - assemblies undergo a degreasing/ phosphating and corrosion preventing process; sheet steel parts are zined; underbodies are carefully primed prior to the application of several coats of enamel; special parts such as joints are protected with a special sealant; boxed sections

are protected against water infiltration by injecting an oil-based compound.

Service

The 370 quality is even more enhanced by the quality of Fiat Service.

A specialist organization is on hand to guarantee the full efficiency of the coach: men, plant, equipment in thousands of service centres throughout the world to make sure all your repair and maintenance jobs are done quickly and that spares are readily available.

FIAT
veicoli industriali

**Fiat Veicoli Industriali:
an IVECO make**



The information contained in this brochure is intended to be of a general nature only. The Fiat Veicoli Industriali S.p.A. may at any time and from time to time, for technical or other necessary reasons, modify any of the details or specifications of the product described in this brochure.

To be sure of getting accurate, detailed and up-to-date information, an intending buyer should consult his nearest Fiat dealer or distributor or branch.

IVECO - Comunicazione e immagine
Edition No. 5.5073 - Printed in Italy
Società Tipografica Piemontese S.p.A.
Torino

