

DAF Bus



**MB200DKFL
& SB2300DHS**



SB2300DHS

The new rear engine SB 2300 DHS coach chassis represents the latest stage of top specification DAF Bus product engineering. Powered by the DAF 8.25 litre turbocharged and intercooled six cylinder diesel engine, which is mounted vertically in the rear of the chassis, this unit produces an impressive 244 nett bhp at 2,400 rpm and 668 lbf. ft. of torque at 1,600 rpm. With all major components and ancillary equipment mounted fore and aft, the all-welded frame construction is ideal for those operators requiring

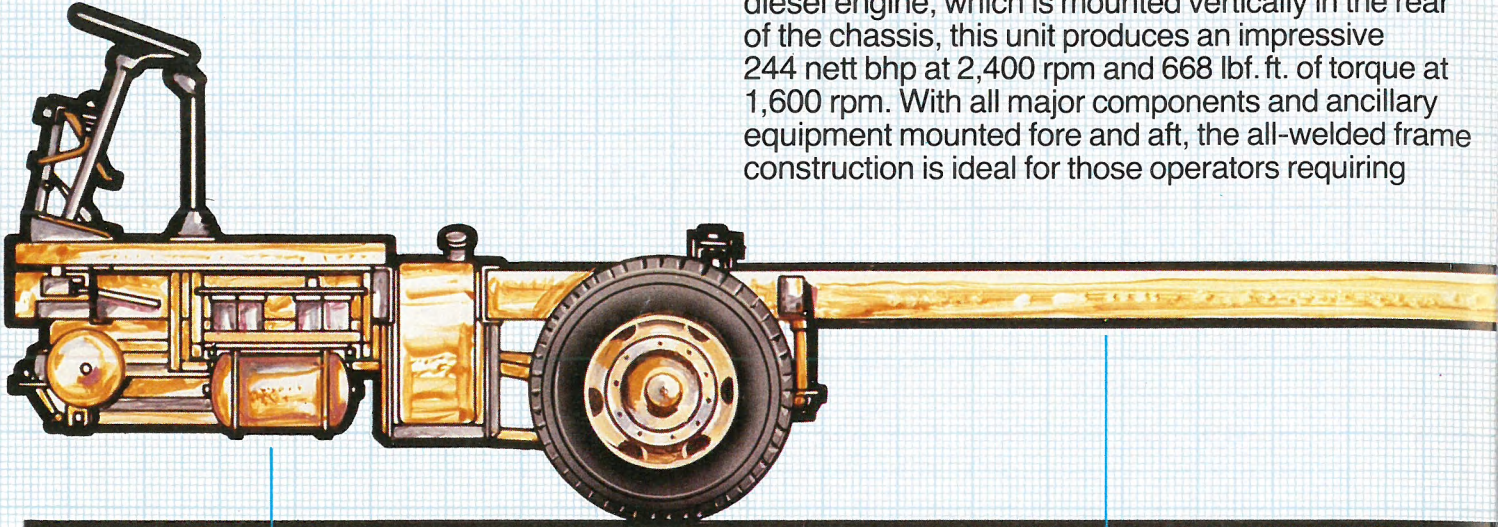

1 Completely updated driver instrumentation and controls. New and revised electrical system. 70 gallons (320 litres) fuel capacity: tanks mounted forward of front axle for maximum stability in this chassis design.

2 DAF N142 front axle, plated at 6,000 kgs design weight, incorporating needle roller bearings. Full air suspension employing a five torque rod, two bellows design with double acting telescopic shock absorbers.

3 Frame is of all welded design entirely suitable for integral/semi-integral construction.

MB200DKFL

With the introduction of the MB 200 DKFL, DAF Bus have brought fully up-to-date their mid engine chassis. Powered by the new DAF 11.6 litre horizontal turbocharged DKFL six cylinder diesel engine, this unit develops a massive 256 nett bhp at just 2,000 rpm; and an equally impressive 794 lbf. ft. of torque at just 1,300 rpm! As with all DAF engines, the DKFL operates on the principal of high torque rise for improved fuel consumption and good mid-range

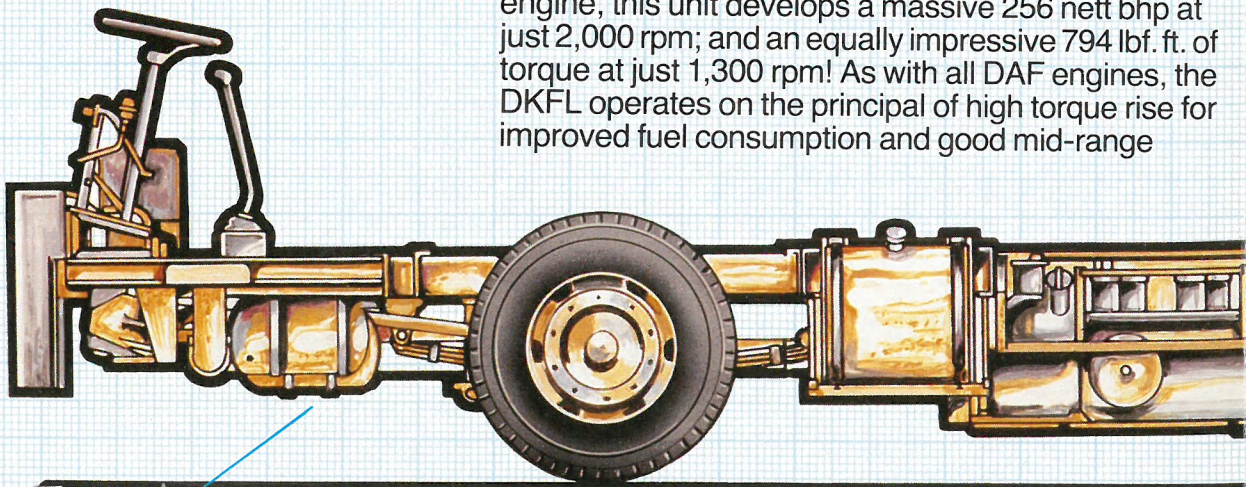

1 Revised driver instrumentation, controls and 24v electrical system. ZF hydraulic power assisted steering. Single dry plate, air assisted hydraulic clutch. DAF N140 needle roller bearing front axle, plated 6500 kgs design gross.

2 Michelin 295/80R 'Pilote' tyres, affording increased stability and lowered rolling resistance. 77 gallons (350 litres) fuel capacity.

Included with both chassis is one year's free membership of the unique DAF Bus Aid, plus second year driveline warranty (PTP 24).

integral or semi-integral vehicle construction. With full air suspension and a twelve speed overdrive synchromesh splitter gearbox, the new DAF SB 2300 DHS represents a new alternative in top specification coaching!

As both the MB 200 DKFL and SB 2300 DHS are fully specified to meet 'Tempo 100' regulations, and feature one of the widest ranges of body options of any chassis manufacturer, DAF Bus is set for the market of the eighties!

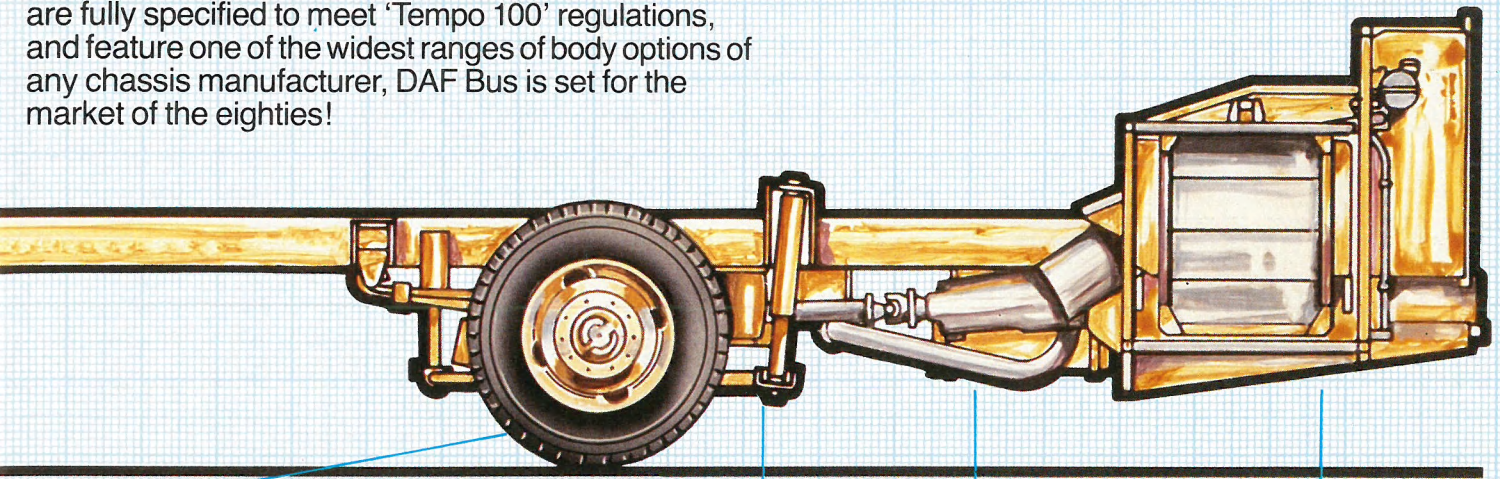

4 Premium Michelin 275/80R 22.5L tubeless tyres. DAF 2255 single reduction, single speed fully floating axle, plated at 10,170 kgs (10 tons) design gross.

5 Full rear air suspension. Trailing arm, 2 bellows design with outboard double acting telescopic shock absorbers. Stabilisers on front and rear axles.

6 ZF S6-80/GV80 six speed synchromesh gearbox with two speed splitter, with overdrive (0.84:1) top gear.

7 DAF DHS 825 vertical six cylinder turbocharged and intercooled in-line diesel engine, developing 244 nett bhp at 2,400 rpm and 668 lbf. ft. of torque at 1,600 rpm. Surrounded by specially developed sound-deadening noise-pack construction for maximum engine quietness.

performance; combined with fast acceleration and high top speed at impressively low engine revolutions.

With a twelve speed overdrive gearbox, air suspension, improved luggage space, revised electrics and engine sound insulation, the new DAF MB 200 DKFL is set to be the new standard for fast and economical long distance cruising. That's performance!

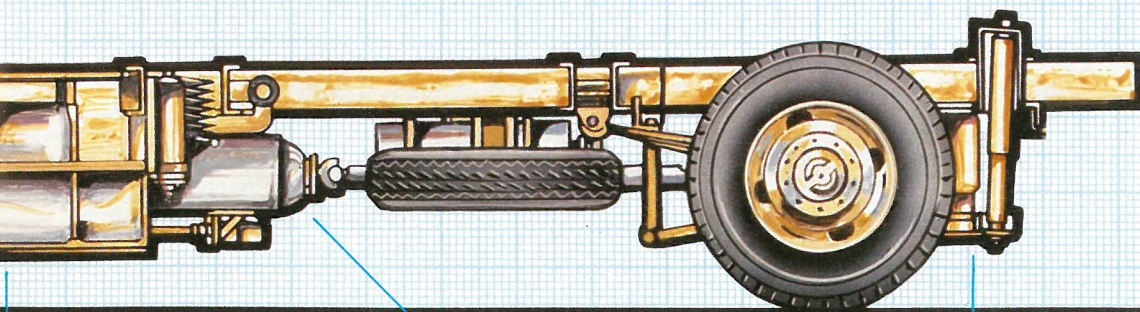

3 DAF DKFL 1160 horizontal six cylinder in-line turbocharged four stroke direct injection diesel engine, developing 256 nett bhp at 2,000 rpm and 794 lbf. ft. torque at 1,300 rpm. Entire engine encased in specially designed sound-deadening noise insulation pack.

4 ZF S6-90/GV90 12 speed splitter synchromesh gearbox, with overdrive top gear (0.82:1).

5 DAF 2255 single reduction, single speed fully floating axle with hypoid bevel bearing, design gross 11,600 kgs (11.4 tons). Full air suspension, employing a trailing arm two bellows design with outboard double acting telescopic shock absorbers. Stabilisers on front and rear axles.

The back-up that makes DAF Bus so special



'The DAF Bus Back-up package' is a unique back-up support service available to all DAF coach operators. No other manufacturer including Leyland, Volvo, Bedford, BOVA and M.A.N. can offer

you such a package as this. The support is complete and covers all DAF coach operators from emergency roadside repair situations to customer workshop courses run by DAF Bus' own experienced instruction team. When you operate a DAF coach, we give the best back-up you've ever seen!



DAFBusAID

A single Freephone call using a number exclusive to DAFBusAID members brings help or advice immediately. A call to the I.T.S. Centre in Holland provides you with the same reliable service on the Continent. Membership to DAFBusAID is provided free of charge in the first year!

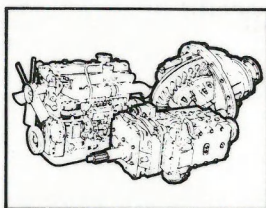

Power Train Protector

Power Train Protector is the DAF Bus guarantee to repair or replace free of charge any defective part of the coach's power train due to faulty materials or manufacture. Free Power Train assurance is provided for a further 12 months after the first year warranty – your guarantee of worry free operation.



Customer Courses

A purpose built workshop training centre is available to promote the high standards for technical training and product skills of DAF Bus customer workshop technicians. Training courses are available for operators' mechanics – all to ensure the highest levels of skills and up to date knowledge of this premium product.

DAF Bus



DAF Bus
Marlow
Bucks. SL7 1LW
Tel: Marlow
(06284) 6955
Telex: 848489

