



Technical Information **The Citaro**



Mercedes-Benz

Model

Citaro (628.083)

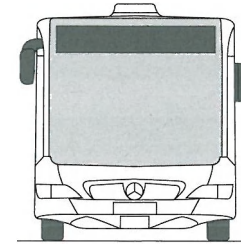
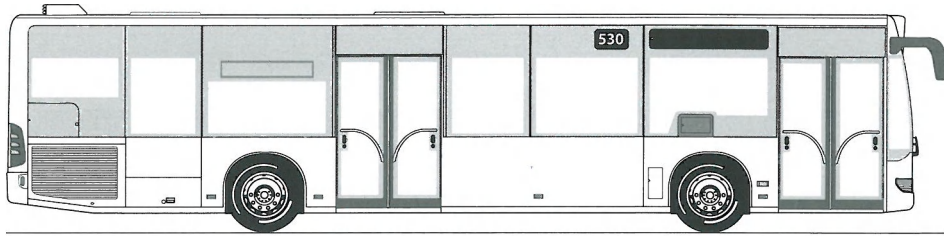

Citaro (628.085)

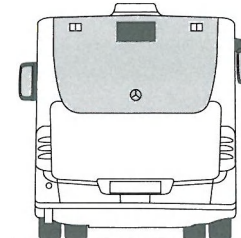
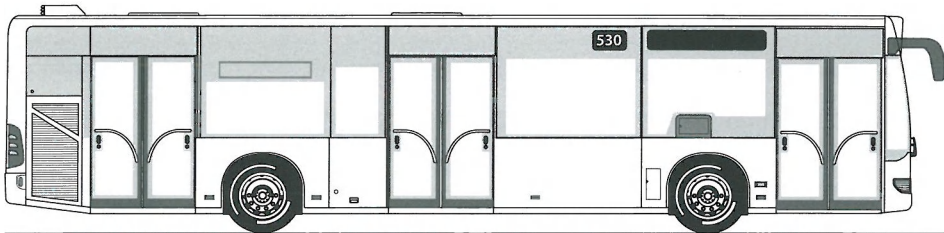

Citaro (628.090)

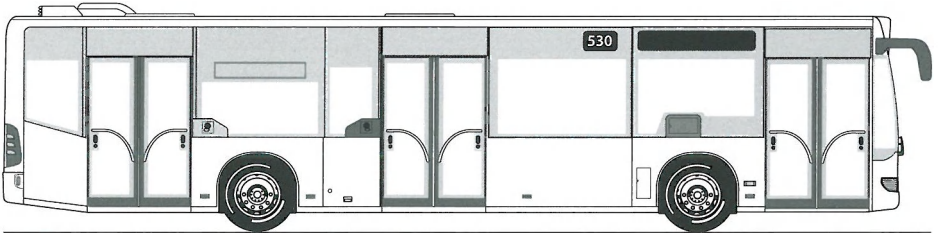

Dimensions/weights

	Citaro, 2 Doors	Citaro, 3 Doors	Citaro, vertical engine
Vehicle length	11,950 mm	11,950 mm	11,950 mm
Vehicle width	2,550 mm	2,550 mm	2,550 mm
Vehicle height (incl. air conditioning system)	3,076 mm	3,076 mm	3,076 mm
Wheelbase, front axle-drive axle	5,845 mm	5,845 mm	5,845 mm
Front/rear overhang	2,705/3,400 mm	2,705/3,400 mm	2,705/3,400 mm
Angle of approach/departure	7°/7°	7°/7°	7°/7°
Tyre size	275/70 R 22.5	275/70 R 22.5	275/70 R 22.5
Passenger handling capacity overall	106	105	101
of which seats	32	28	26
of which standing places	74	77	75
Step height, Door 1/Door 2/Door 3	320/340/- mm	320/340/340 mm	320/340/340 mm
Clear door width	1,250 mm	1,250 mm	1,250 mm
Standing height front/rear	2,313/2,082 mm	2,313/2,044 mm	2,313/2,314 mm
Height of floor above road surface	370 mm	370 mm	370 mm
Platform height	280 mm	280 mm	280 mm
Waistline height (above floor)	950 mm	950 mm	950 mm
Fuel tank capacity	280 l	280 l	280 l
Capacity of AdBlue additive tank	38 l	38 l	38 l
Gross vehicle weight, max. permissible*	18,000 kg	18,000 kg	18,000 kg
Axle loads, max. permissible*			
-Front axle	7,245 kg	7,245 kg	7,245 kg
-Drive axle	12,000 kg	12,000 kg	12,000 kg

* dependent on country of registration - example here is Germany

Turning circle

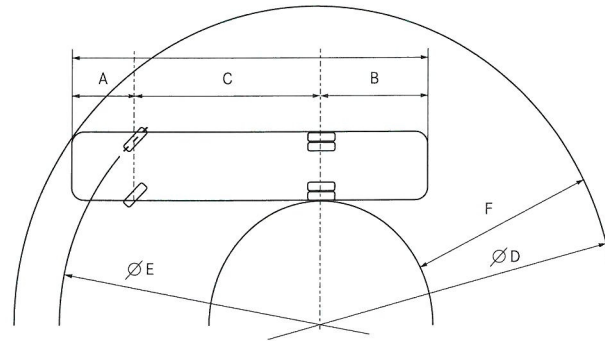

	Citaro, 2 Doors	Citaro, 3 Doors	Citaro, vertical engine
A: Front overhang	2,705 mm	2,705 mm	2,705 mm
B: Rear overhang	3,400 mm	3,400 mm	3,400 mm
C: Wheelbase	5,845 mm	5,845 mm	5,845 mm
D: Minimum turning circle	21,030 mm	21,030 mm	21,030 mm
E: Minimum track circle	16,908 mm	16,908 mm	16,908 mm
F: Swept annular width – minimum turning circle	6,758 mm	6,758 mm	6,758 mm
D: BOKraft turning circle	25,000 mm	25,000 mm	25,000 mm
F: BOKraft swept annular width	5,776 mm	5,776 mm	5,776 mm
F: Maximum permissible swept annular width according to BOKraft	7,200 mm	7,200 mm	7,200 mm
Maximum front axle turning angle, inside/outside wheel	53°/46°	53°/46°	53°/46°

Drive train/Technology

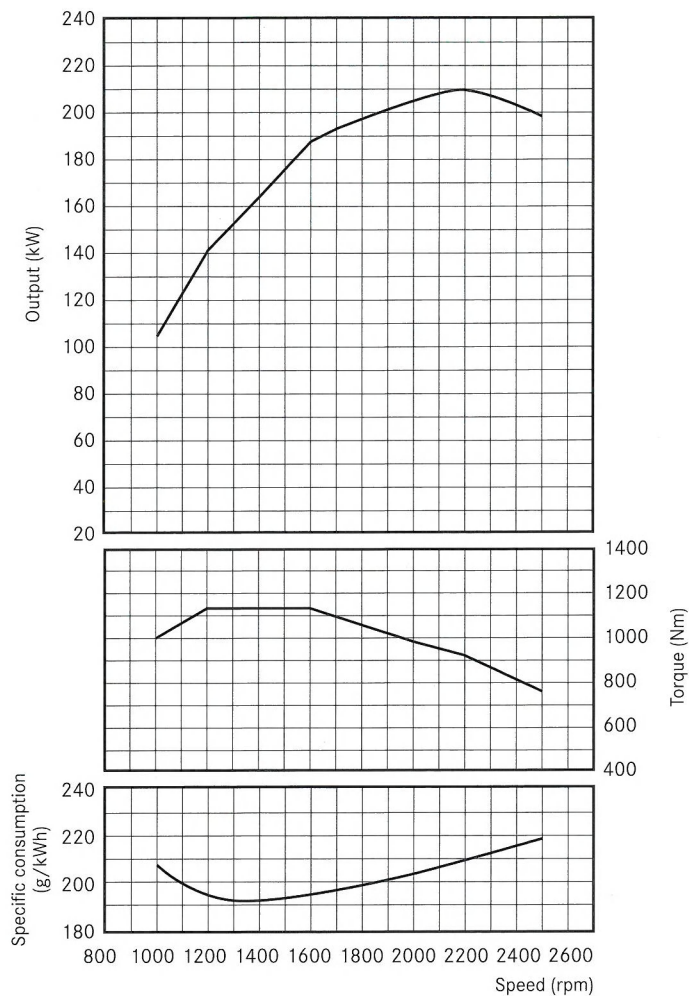

P_{max} 210 kW at 2200 rpm (80/1269/EEC)

T_{max} 1120 Nm at 1200-1600 rpm, $T_{trans} = 23\%$

Steady-state full-load curves

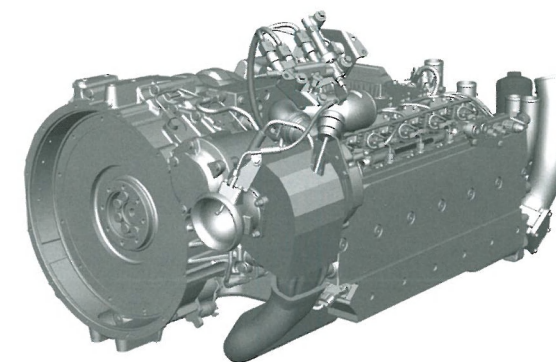
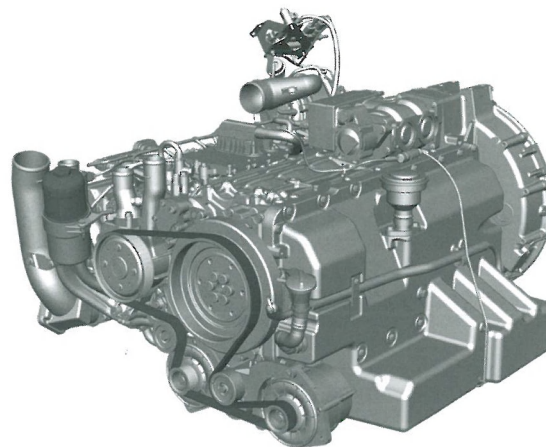

	Citaro, 2 Doors	Citaro, 3 Doors
Engine (Euro V/EEV*)	OM 906 hLA	OM 906 hLA
Displacement	6,370 cm ³	6,370 cm ³
Output (standard)	210 kW	210 kW
Cylinders/arrangement	6/in-line	6/in-line
Max. torque	1,120 Nm at 1,300 / min	1,120 Nm at 1,300 / min
Transmission	VOITH DIWA 5.0, 4-speed	VOITH DIWA 5.0, 4-speed
Axles		
Front axle	ZF, independent wheel suspension	ZF, independent wheel suspension
Drive axle	ZF AV 132	ZF AV 132
Steering	ZF power steering	ZF power steering
Brakes	Electronic Braking System with disk brakes Anti-lock Braking System (ABS)	

* Our buses meet the EEV emission standard with or without a diesel particulate filter, depending on model and power unit.

Drive train/Technology

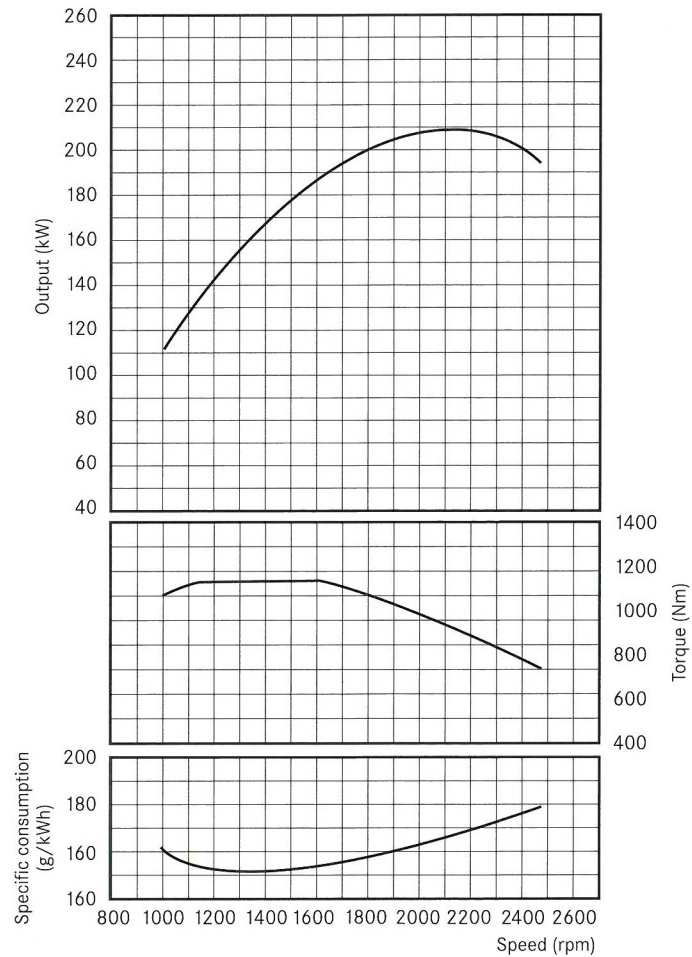

P_{\max} 210 kW at 2200 rpm (80/1269/EEC)
 T_{\max} 1120 Nm at 1200-1600 rpm, $T_{\text{trans}} = 19\%$

Steady-state full-load curves

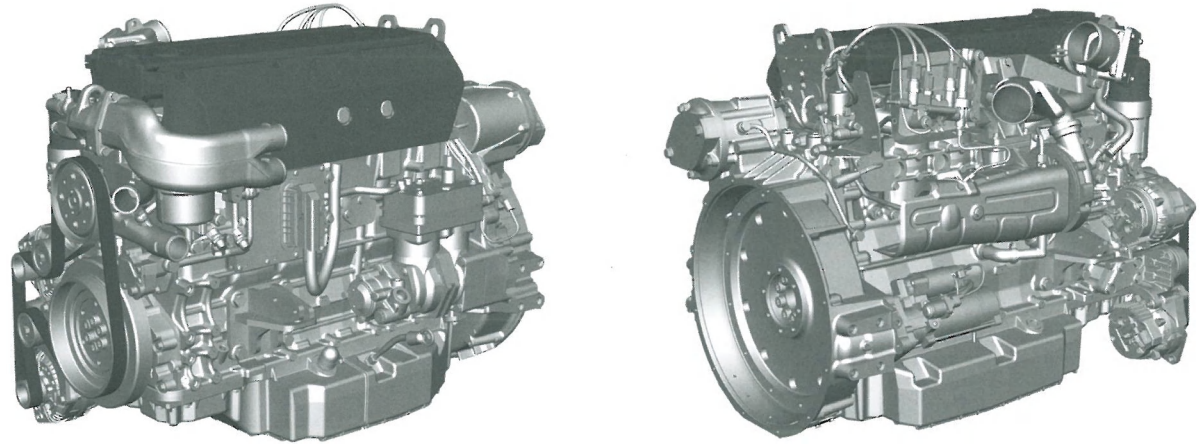

Citro, vertical engine

Engine (Euro V/EEV)	OM 926 LA
Displacement	7,200 cm ³
Output (standard)	210 kW
Cylinders/arrangement	6/in-line
Max. torque	1,120 Nm at 1,300 / min
Transmission	VOITH D 854.3, 4-speed
Axles	
Front axle	ZF, independent wheel suspension
Drive axle	ZF AV 132
Steering	ZF power steering
Brakes	Electronic Braking System with disk brakes Anti-lock Braking System (ABS)

Seating variants Citaro (C.628.083)

Standard

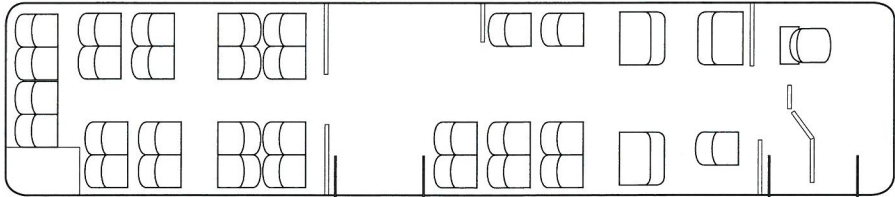

Number of seats 32

Extra (example)

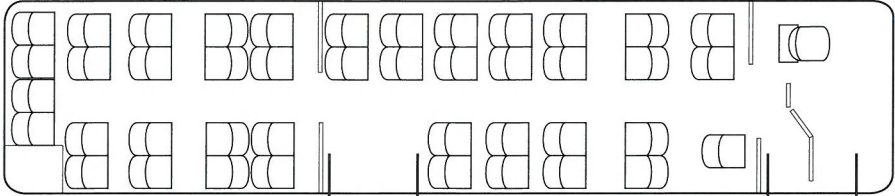

Number of seats 43

Extra (example)

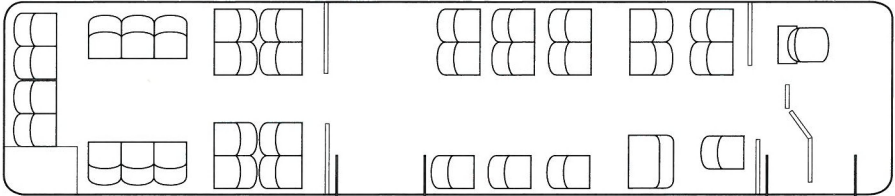

Number of seats 33

Seating variants Citaro (C.6280.085)

Standard

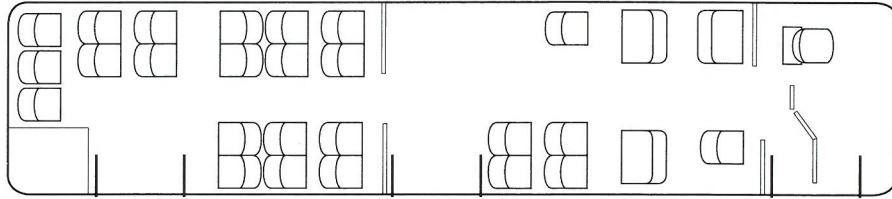

Number of seats 28

Extra (example)

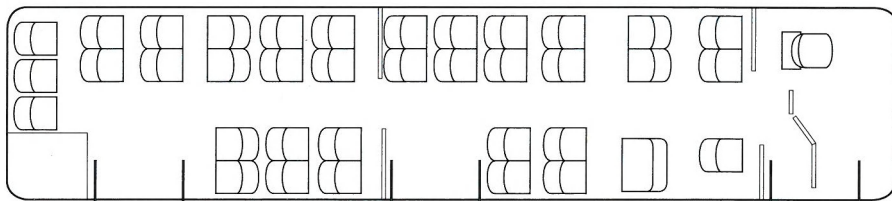

Number of seats 37

Extra (example)

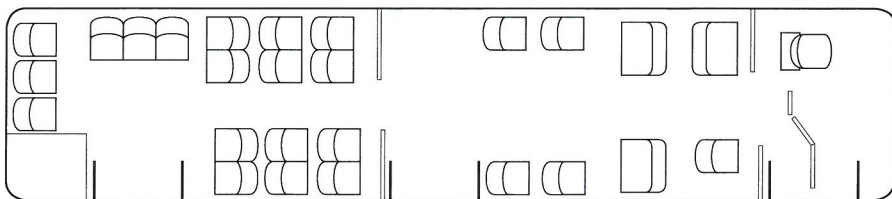

Number of seats 26

Seating variants Citaro (C.628.090)

Standard

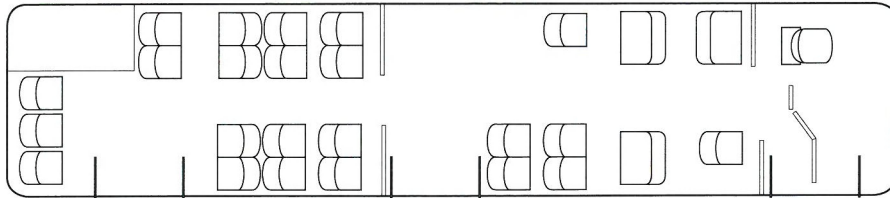

Number of seats 26

Extra (example)

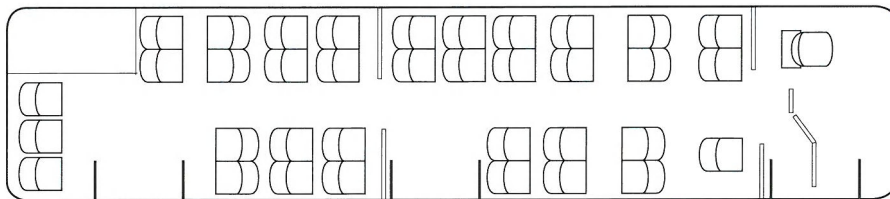

Number of seats 36

Extra (example)

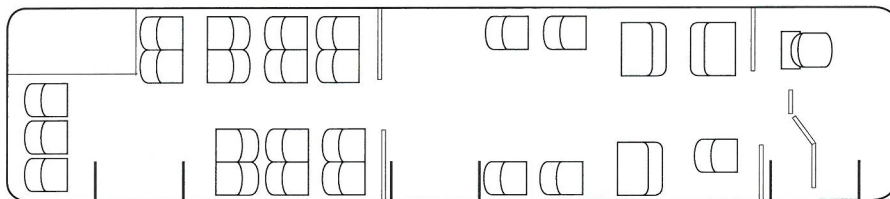

Number of seats 25

Standard and optional equipment (selected)

Engine and running gear	Citaro, 2 Doors	Citaro, 3 Doors	Citaro, vertical engine
Engine Mercedes-Benz OM 906 hLA 210 kW (Euro V)	●	●	-
Engine Mercedes-Benz OM 926 LA 210 kW (Euro V)	-	-	●
Engine Mercedes-Benz OM 457 hLA 220 kW (Euro V)	○	○	-
Engine Mercedes-Benz OM 457 hLA 260 kW (Euro V)	○	○	-
Emission standard EEV	○	○	○
Automatic transmission VOITH DIWA 5.0, 4-speed	●	●	●
Automatic transmission VOITH DIWA 5.0, 4-speed	-	-	-
Automatic transmission ZF Ecomat, 6-speed	○	○	●
Automatic transmission ZF Ecolife, 6-speed	-	-	○
Electronic braking system (EBS)	●	●	●
Anti-lock Braking System (ABS)	●	●	●
Anti-Slip Regulation (ASR)	○	○	○
Automatic bus stop brake with starting-off lock	●	●	●
Air suspension via electronic level control system (ENR)	●	●	●
Vehicle lift 70 mm, with button on instrument panel/console	○	○	○
Painted rims/painted hub caps	○	○	○
Hub caps made of plastic	○	○	○
Hub caps made of stainless steel	○	○	○

● Standard equipment/Equipment at no extra charge ○ Extra

	Citaro, 2 Doors	Citaro, 3 Doors	Citaro, vertical engine
Air conditioning			
Turbo ventilator	●	●	●
Roof duct ventilation system with integral heating	○	○	○
Roof-mounted air conditioning system, heavy-duty version or hot country version	○	○	○
Electrically operated roof hatch with automatic closing (windscreen wiper operation, engine off)	●	●	●
Heating with side panel heating units	●	●	●
Heater with convectors	○	○	○
Driver's area			
Driver's seat GRAMMER Tourea MSG 90.6, air-sprung	●	●	●
Driver's seat ISRI 6860/875, integrated pneumatic system, 3-point seat belt	○	○	○
Seat heater for driver's seat	●	●	●
Driver area air conditioning	○	○	○
Driver's cab door	●	●	●
Compartment for driver's bag at cab door, open	●	●	●
Compartment for driver's bag at cab door, lockable, foldable	○	○	○
Provision for a ticket machine printer	●	●	●
Steering column with height and tilt adjustment, steering wheel lock	●	●	●
Cruise control	○	○	○
Heated exterior mirror	●	●	●
Exterior mirrors heated, electrically adjustable with school bus approval	○	○	○
Driver's microphone	○	○	○
Reversing buzzer	○	○	○
Blind across 2/3 of windscreen, electrically operated	○	○	○
Camera surveillance of interior	○	○	○
Fire detection system for engine compartment monitoring	●	●	●
Extinguisher system	○	○	○

● Standard equipment/Equipment at no extra charge ○ Extra

Interior	Citaro, 2 Doors	Citaro, 3 Doors	Citaro, vertical engine
Seating: City Star Eco (CSE)	●	●	●
Wheelchair space	○	○	○
Wheelchair back area wall with integrated fold-up seat	○	○	○
Stop request button	●	●	●
Stowage on front left/right wheel arch	○	○	○
Emergency hammers secured with rope, automatic retractor	●	●	●
Emergency hammers with electric anti-theft device	○	○	○
Sidewall covering in textured felt	○	○	○
Clothes hooks on window pillars	○	○	○
Other			
Halogen front fog lamps, integrated in bumper	○	○	○
Side windows heat-absorbing, grey tint	○	○	○
Double glazed side windows	○	○	○
Hinged panes in side windows	●	●	●
Sliding panes in side windows	○	○	○
Folding ramp at Door 1 or 2, mechanical	○	○	○
Modular ramp at Door 2, mechanical or electric	○	○	○
Ski box bracket	○	○	○
Information systems			
Radio system with CD player	○	○	○
Multi-function antenna for radio, mobile phone, navigation	○	○	○
Bus stop display inside, in cross duct	○	○	○
Destination system LCD or LED	○	○	○
Wheelchair button inside/outside	○	○	○
GPS digital clock on front-end flap/in roof cross duct	○	○	○

● Standard equipment/Equipment at no extra charge ○ Extra

Technical modifications may have occurred after the copy deadline. This data sheet is only an extract of possible equipment. Some equipment items are country-dependent. We reserve the right to make technical modifications. Therefore, please contact your Mercedes-Benz sales representative for the latest binding version.

Glossary

Anti-lock Braking System (ABS)

The braking forces acting on the individual wheels are distributed by the ABS so that even in an emergency braking situation no wheel is blocked for any length of time and the steerability of the bus is largely maintained.

Anti-Slip Regulation (ASR)

ASR prevents wheelspin when driving away on a slippery surface. It provides no more power than the drive wheels are able to transfer to the road surface. Wheelspin by one wheel – e.g. on an icy roadside – is prevented by metered braking.

Electronic level control

Passengers and luggage are not always evenly distributed in the vehicle. As a result, the height of the vehicle varies from wheel to wheel. The electronic level control automatically regulates the vehicle height at each wheel so that the step height is always the same.

Electronic Braking System (EBS)

EBS is a further development of the conventional air brake and offers numerous advantages. When braking, the control unit first activates the retarder. If greater deceleration is required, the control unit uses the information in the data network to determine the optimum braking pressure for every axle.

The electronic braking system thus results in much shorter stopping distances and significantly less brake disc and lining wear.

Cataphoretic Immersion Priming (KTL)

Cataphoretic immersion priming (KTL) is an electro-chemical process for coating the complete body shell in an immersion bath. It is ideal for painting complicated structures and large numbers of units. This water-based paint protects the vehicle so perfectly against corrosion because the paint coat is applied everywhere to the body with uniform thickness. Cataphoretic immersion priming is demonstrably the best protection against corrosion in vehicle construction at present available.

For further information, contact your Mercedes-Benz Buses and Coaches representative.
Or visit us online at www.mercedes-benz.de/omnibus

The illustrations also depict extras and accessories that are not part of the standard scope of supply.
The technical information in this brochure applies to Germany. (Status: July 2010). We reserve the right to make production changes.