



# Travego RH

Welcome to business class



Mercedes-Benz



## Comfort from Monday to Sunday

The Travego RH is the touring bus for every day. Its forte is a high level of comfort, consistent economy, attractive design and reliable, state-of-the-art technology. One that understands your business.

Whether for a demanding cultural heritage tour, a weekend excursion, an evening visit to the theatre or for long-distance routes, the Travego RH is ideal for many requirements. It will soon become an essential part of your fleet. It will also be well received by your passengers. Its outstanding modern styling ensures an all-star reception in every venue. The elegant exterior corresponds completely with the interior which is intended

for passenger comfort. The standing height of 2.10 m even permits exceptionally tall people to stand upright. Apart from the driver and one hostess, there is space for 49 passengers in the 3-star version, of course with their luggage, since the Travego RH has a copious luggage compartment. Platforms and seats in way of the centre door can be removed. In this way, where required, you can easily set up a standing area.





**Comfortable from front to back**

In the Travego RH, your passengers travel on comfortable seats with grab handles and lap belts. Hooks for clothing and bags are integrated in the seat backs. At your request, the passenger seats can be made even more comfortable by means of adjustable seat backs, luggage nets and other extras. A high degree of comfort is also ensured by the service sets over the seats. They permit individual lighting, ventilation and adjustment of the sound system level at the passenger seats. So that your passengers feel well in the Travego RH whatever the weather, its standard equipment includes thermally insulating wrap around glazing as well as powerful convector heating and reliable ventilation. An air-conditioning unit is available as optional equipment. In addition, the fitment of a mini-galley or a toilet.

**A triple variety of features**  
Equip the Travego RH so that it complies with your demands and the application. That's really simple with the three equipment lines Function, Fashion and Flair.

**Function:** the classical line. It is characterized by a timeless, discreet design and is ideal for a combination of public service traffic, taking school children from A to B and for excursions.

**Fashion:** the fashionable alternative, that is particularly attractive for younger passengers. Ideal for event trips, snowboarding weekends or for visits to pop concerts.

**Flair:** this is the variant for high-quality elegance. It satisfies upmarket demands where appearance and comfort are concerned. Flair is recommended especially for city tours or for cultural heritage tours.





Top:  
*Let's go: Three steps with anti-slip covering lead inside from the centre door.*

left:  
*Interior space: There is enough space in the luggage compartment for the luggage of your passengers.*

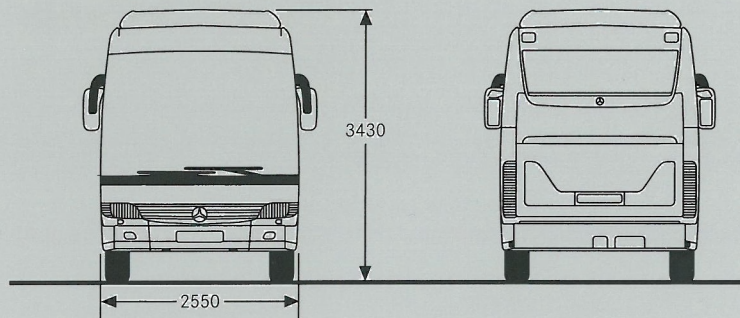
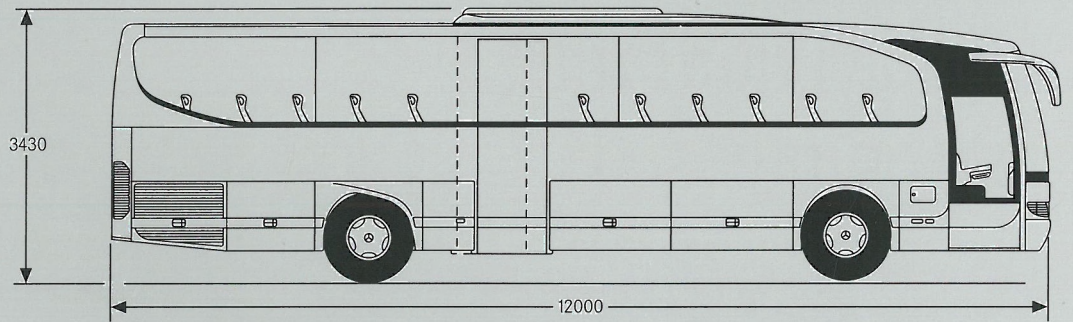



## Your accountant will be pleased

Low costs, higher performance - with the Travego RH you won't be taking any chances. That's because state-of-the-art technology ensures low life cycle costs and highest safety.

The Travego RH will win over the most cautious accountants due to its favourable purchase price and its comfortable standard layout. Long servicing intervals permit brief down-times. An additional blessing for your budget is the economic and sturdy 6-cylinder in-line engine OM 457 hLA with 260 kW (354 bhp) or on request with 300 kW (408 bhp). Naturally, both engines comply with the stringent Euro 3 standards. The transmission

is a mechanical MB 6-speed joystick circuit with pneumatic gearshift. It ensures a smooth, easy gear change.

The Travego RH is not only economic but also safe. The disc brakes on all four wheels comply with the highest standards. ABS and ASR are fitted as standard. In addition, the Travego RH is also equipped with an electro-pneumatic braking system (EBS) for even shorter stopping distances.



*Particularly practical for long-distance public service: the double-leaf outwards opening door. This is only one of the many possibilities from the extensive range of special accessories for the Travego RH.*

# The Travego RH in figures

<b>Model</b>	<b>15RH</b>
Length	12,000 mm
Width	2,550 mm
Vehicle height (approx.)	3,430 mm
Turning circle	20,800 mm
Wheelbase	6,080 mm
Front overhang	2,620 mm
Rear overhang	3,300 mm
Tyre size	295/80 R 22.5
Height of driver's position	860 mm
Standing height in aisle	2,100 mm
Waistline height (above platform)	755 mm
Step height Door I, Door II	3x170 mm
Height of step with 295/80 R 22.5 tyres	315 mm
Height of floor with 295/80 R 22.5 tyres	1,040 mm
Platform height	150 mm
Angle of approach	7.4°
Angle of departure	6.7°
Door I, Door II (double door)	
Portal width	900 mm, 1,380 mm
Interior aisle width	770 mm, 1,230 mm
Luggage bay capacity	
without toilet	approx. 7 cubic metres
with toilet	approx. 6 cubic metres
3 star seating	1/1/49
Seat divider, min.	770 mm
Engine	OM 457 hLA
Rating	260 kW (354 bhp)
Cylinders/cylinder arrangement	6 in-line
Displacement	12,000 cm <sup>3</sup>
Max. torque	1,600 Nm
Transmission (6-speed)	MB GO 190
Tank capacity	410 l
Engine (option)	OM 457 hLA
Rating	300 kW (408 bhp)
Max. torque	1,900 Nm
Transmission (6-speed)	MB GO 190

Contact your Mercedes-Benz bus representative for more information. Or visit us on the Internet at:  
[www.mercedes-benz.com](http://www.mercedes-benz.com)

The illustrations also depict extras and accessories that are not part of the standard scope of supply. The information in this catalogue applies to Germany.

Colour variations are due to printing technology (Version: 01.06.00). We reserve the right to make production changes.

EvoBus GmbH, Mercedes-Benz Omnibusse, VM6098.1019.02.00/0403/01 Printed in the Federal Republic of Germany / Imprimé en République fédérale d'Allemagne

EvoBus GmbH, Mercedes-Benz Omnibusse, Hanns-Martin-Schleyer-Str. 21-57, D-68301 Mannheim, Germany, Phone: +49 (0)6 21/740-0, Fax: +49 (0)6 21/740-42 51